

Service Manual

WQ-200 WALL BOX

SERVICE MANUAL
WQ-200 WALL BOX

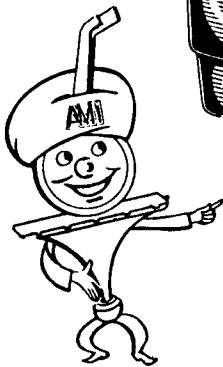
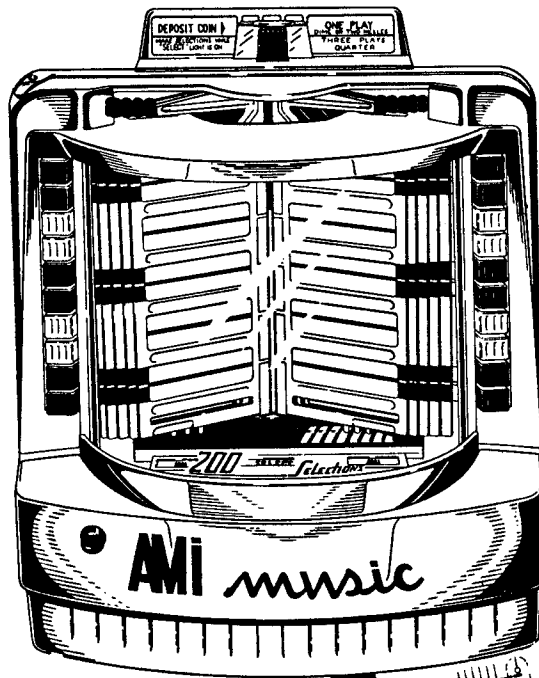

SWAMI

"Service
With
AMi"

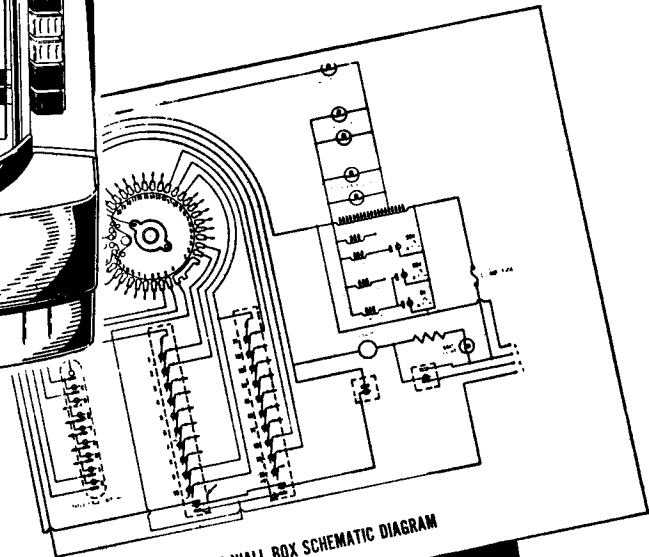

AMi Incorporated

1500 UNION AVENUE, S. E.
GRAND RAPIDS 2, MICHIGAN

CONTENTS

	Page No.
GENERAL	2
PRINCIPLES OF OPERATION	2 thru 8
Credit Unit	4
Home and Credit Position	5
Wait Light & A.C. Control Circuit	6
Credit Light	6
Slug Rejector & Coin Switches	6
Connecting Wall Boxes	6, 7, 8
MECHANICAL ADJUSTMENT DATA	9 thru 11
Motor Control Switch	9
Wiper Arm Positioning.....	10
Pushbutton Banks	10
Pushbutton Contacts & Starting Switch Adjustment	10
Mounting The WQ-200 Wall Box	10

GENERAL

The WQ-200 WALL BOX is designed to operate as remote control equipment for the G-200 Phonograph. The function of the WALL BOX is to control a series of low voltage, direct current pulses which are sent to the PULSE CONVERTER of the PHONOGRAPH. The PULSE CONVERTER then translates these

pulses into proper selections.

WALL BOXES are connected to the phonograph through a four-wire cable. A four terminal BARRIER STRIP in the WALL BOX and one in the lower compartment of the PHONOGRAPH are used to make the cable connections which ties the two units together.

PRINCIPLES OF OPERATION

Fundamentally, the WALL BOX is comparable to a switch which closes its contacts repeatedly completing the circuit through which direct current will flow in the form of pulses to the PULSE CONVERTER. The direct current is supplied to the PULSE CONVERTER by a TRANSFORMER-RECTIFIER com-

bination in the MAIN JUNCTION BOX. This DC circuit is connected to the WALL BOX through two wires in a four-wire cable. The WALL BOX turns the DC off and on by the rotation of a WIPING ARM (See Fig. 1 (A) whose contacts alternately close and open the DC circuit through the commutator segments which its contacts cross.

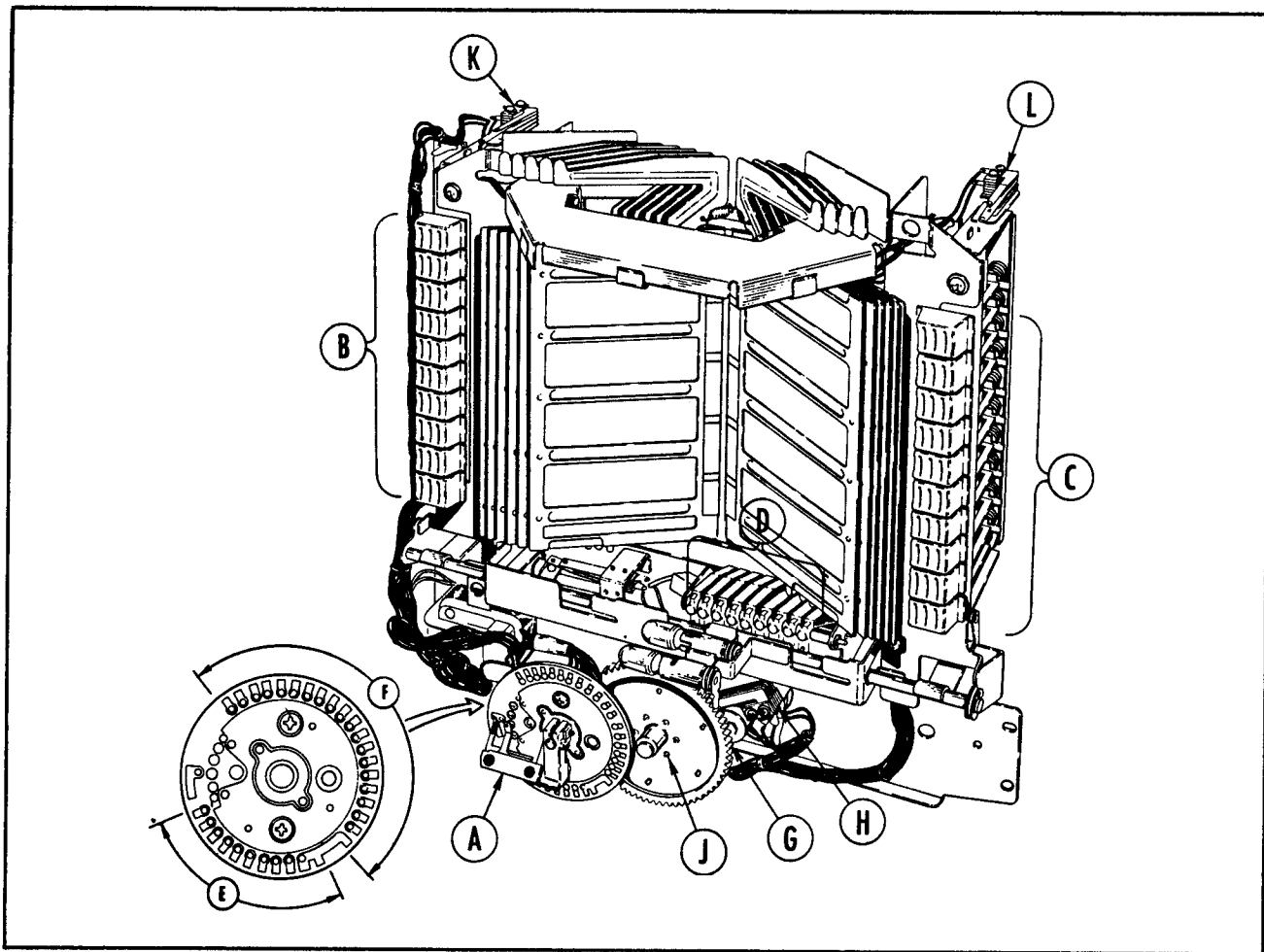

FIGURE 1.

The WIPING ARM is driven by a motor and its contacts sweep across segments which are imbedded in a COMMUTATOR PLATE. The spacing of these segments is such that if the WIPING ARM is driven at a constant rate, the closing and opening of the DC circuit will produce uniformly spaced "off and on" periods. The uniformly spaced "off and on" periods are known as pulses. The arrangement is such that the pulses are grouped into two trains so that the interval between trains is longer than that between individual pulses. By an arrangement of external switches, the segments of the commutator can be switched in or out of the circuit thus making it possible to control the number of pulses generated in each train.

In making use of these principles, the WALL BOX commutator segments are connected to two different groups of switches. One group, the PUSHBUTTON BANK SWITCHES, consists of two separate banks of ten switches each. (See Fig. 1 (B & C). The second group consists of nine series connected TITLE PAGE SWITCHES (D). These TITLE PAGE SWITCHES are actuated by the turning of the TITLE PAGES. The TITLE PAGE SWITCHES connect the COMMUTATOR SEGMENTS which make up the first group of eleven segments on the COMMUTATOR DISC (E). The PUSHBUTTON SWITCHES connect the second series of twenty segments of the COMMUTATOR DISC (F). By means of opening and closing switches in the two groups, two hundred different pulse combinations are available.

The motor in the WALL BOX is a small AC gear motor which turns its output shaft at approximately 22 rpm. It is equipped with a spring loaded, magnetic clutch so that the motor shaft will not coast when the current is turned off. Current for the motor as well as for the LIGHTS and CREDIT MAGNETS is supplied by the TRANSFORMER-FUSTAT ASSEMBLY in the bottom compartment of the phonograph. Twenty-six volts AC is carried from the PULSE CONVERTER to the WALL BOX by two conductors in the four wire connecting cable. Since the AC and the DC pulses must both be carried from the PULSE CONVERTER to the WALL BOX, one wire is common for both types of current flow.

Three WIPING BLADES are mounted on the WIPER ARM which mounts on the end of the GEAR MOTOR SHAFT (See Fig. 2). For each operation of the WALL BOX, the MOTOR SHAFT and WIPER ARM make one complete revolution. The WIPING BLADE on the tip of the WIPING ARM (A) is the blade which makes contact with the uniformly spaced segments at the outer edge of the COMMUTATOR DISC and carries the DC pulses. The center WIPING BLADE (B) makes contact with the large brass plate on the disc and also the home and credit position rivets. It carries the AC current necessary to drive the WALL BOX

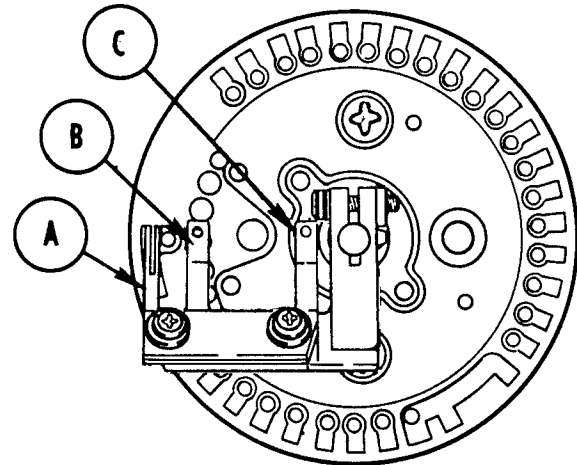

FIGURE 2.

GEAR MOTOR. The third WIPING BLADE (C) makes contact with the small ring at the center of the COMMUTATOR DISC. This blade is common for the AC and DC pulses.

The TITLE PAGE SWITCHES control the number of current pulses that will be produced as the WIPING BLADE scans the first eleven signalling segments on the COMMUTATOR DISC. With the TITLE PAGES so positioned that the "K" pages are exposed, all of the TITLE PAGE SWITCHES will be closed and eleven pulses will be transmitted from the WALL BOX as a result. This will cause the PULSE CONVERTER to make some selection in the "K" series. If the TITLE PAGES are turned so that the "A" pages are exposed all TITLE PAGE SWITCHES will be open and only two pulses in the first series will be transmitted to the PULSE CONVERTER resulting in some selection in the "A" series being made.

(The remaining signalling segments, Numbers 1-20, are connected in order to the series connected, normally closed PUSHBUTTON SWITCHES). If all of these switches are closed when the WIPER ARM scans the segments, twenty pulses will be transmitted in the second series. If all the switches are open, only one pulse will be transmitted in the second series. Thus, with all switches (title page switches and pushbutton switches) in their closed positions, eleven pulses will be transmitted in the first group and twenty pulses will be transmitted in the second group. (The selection registered as a result would be K-20). If all switches are open (title page switches and pushbutton switches) two pulses will be transmitted in the first group and one pulse in the second group. (The selection registered as a result would be A-1).

CREDIT UNIT

The function of the CREDIT UNIT (See Fig. 1 (G) and Fig. 3) is to allow the WALL BOX to be operated a given number of times corresponding to the value of the coin which was deposited. Credits are not accumulated as a result of depositing several coins, one after another, but rather are limited to the largest number which can be established by depositing a single coin. Depending upon the coin denomination and upon the position of the CREDIT MAGNETS, the CREDIT UNIT will establish a certain number of credits.

In effect, the CREDIT UNIT serves to turn on the WALL BOX when a coin is deposited and to turn it off when all credits have been used. The switch which actually serves this function is called the MAIN CREDIT SWITCH (See Fig. 1, (H) or Fig. 3, (A), and is mounted on the CREDIT UNIT base. Closure of the MAIN CREDIT SWITCH contacts occurs when a COIN SWITCH is tripped. When the COIN SWITCH is tripped, a CREDIT MAGNET (See Fig. 3, (1, 2, 3 or 5)) is energized, causing one of the DRIVE PLUNGERS (Fig. 1, (J) or Fig. 3, (B), mounted in the hub of the CREDIT UNIT gear to be released. The moving plunger in turn moves the molded nylon SWITCH ACTUATOR (See Fig. 3, (C), so as to close the switch contacts.

All of the DRIVE PLUNGERS pass over the NYLON RESET as the CREDIT UNIT GEAR rotates. Any tripped plunger will be reset at this point. With all DRIVE PLUNGERS reset, the SWITCH ACTUATOR returns to its normal position and the MAIN CREDIT SWITCH contacts re-open.

Six DRIVE PLUNGERS and their ACTUATING LEVERS are equally spaced above the hub of the gear. The position of each plunger corresponds to a given number of credits when the gear is in the "no credit" or "home" position. The plunger representing one credit will be the first to pass over the reset as the gear rotates. This will occur as the gear turns 1/6 of a revolution. (This 1/6 revolution corresponds to one complete revolution of the WIPER ARM which scans the signalling segments). The plunger in the three credit position, will not be reset until the gear has rotated 3/6 of a complete revolution. This amount of rotation would require three selection cycles of the WALL BOX. Since the position of the DRIVE PLUNGER corresponds to a specific number of credits, a particular plunger must be tripped by that particular CREDIT MAGNET which is energized by a coin having the value corresponding to the same number of plays. For example, if three plays are to be given for 25¢, the 25¢ coin switch must energize the magnet in the three credit position. This will in turn, set the drive plunger in the three credit position.

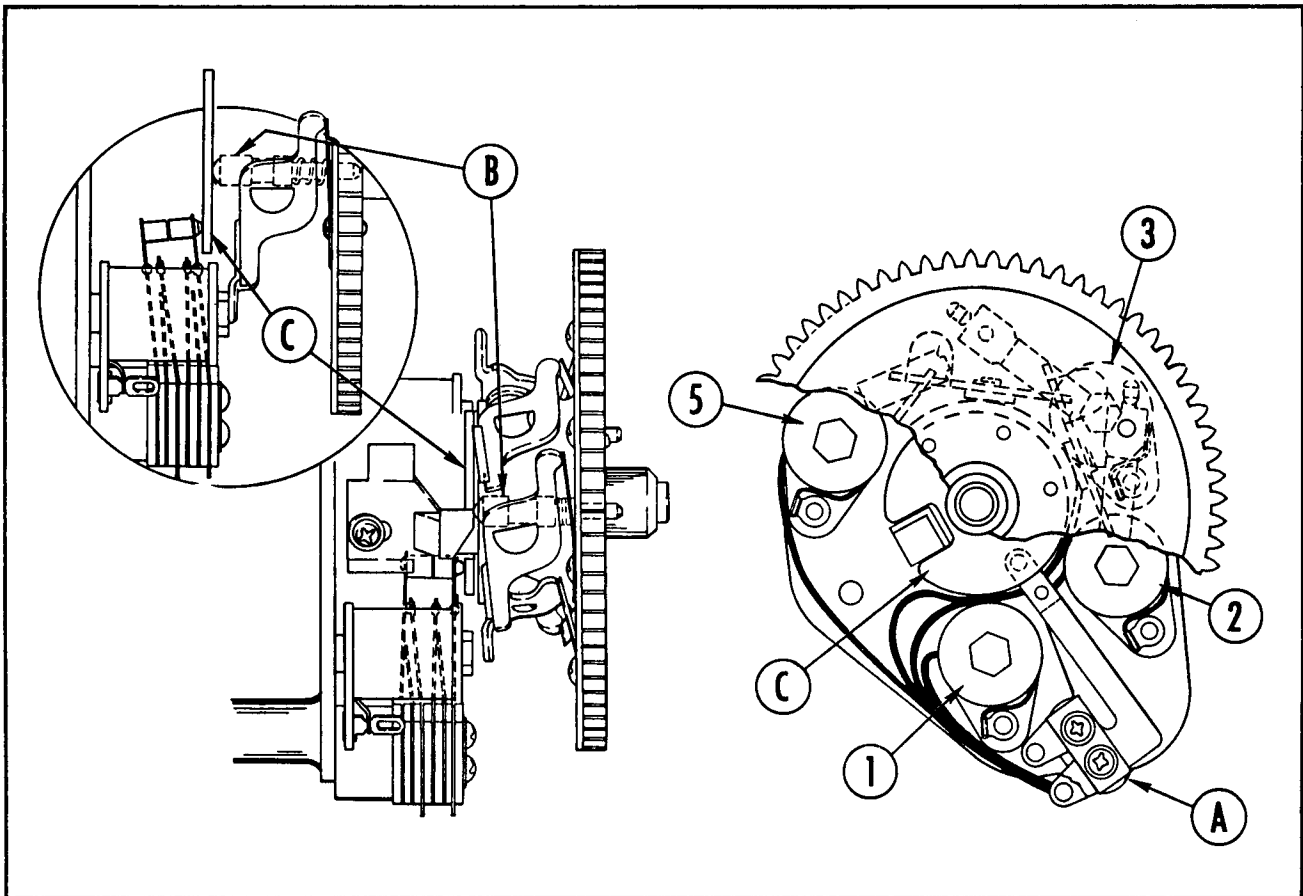

FIGURE 3.

HOME AND CREDIT POSITION

All moving parts in the WALL BOX return to the same initial position after a complete cycle of operation. This position we will call "home position". At this point, all pushbuttons are unlatched and none can be latched in. The two STARTING SWITCHES (See Fig. 1, (K) and (L), at this point, are open. The deposit-

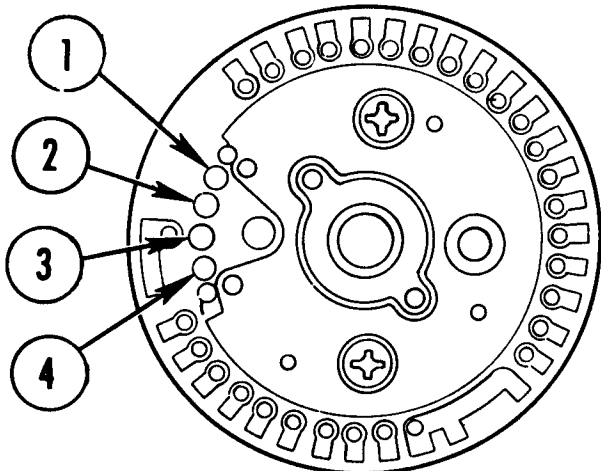

FIGURE 4.

ing of a coin will result in the closure of the MAIN CREDIT SWITCH contacts. At this point, the circuit

to the motor will be completed through the WIPER ARM blades and the first two of a group of four large rivets on the COMMUTATOR DISC. (See Fig. 4). The motor will run until the WIPER ARM blade moves off the second rivet and onto the third. This breaks the circuit and the motor will stop. This position of all moving parts is called the "credit position". At this point, an eccentric CAM (See Fig. 5, (A) on the motor shaft actuates a SHAFT AND LEVER ASSEMBLY (B) which in turn operates the latch bars (C) & (D) in the PUSHBUTTON SWITCH BANKS. Pushing a pushbutton now will result in its being latched in.

From the credit position, the motor is started by the actuation on one of the two STARTING SWITCHES (E) or (F). Depressing a PUSHBUTTON when in credit position will result in the closure of one of the STARTING SWITCHES. The closure of one of these STARTING SWITCHES will cause the GEAR MOTOR to begin to run again. Just before the wiper blade moves off the last of the four large rivets, it contacts the brass plate on the commutator. This completes a circuit to the GEAR MOTOR which is independent of the rivets. As a consequence, the WIPER ARM turns one full revolution and stops again as the WIPER BLADE moves off the brass plate and on to the home position rivets.

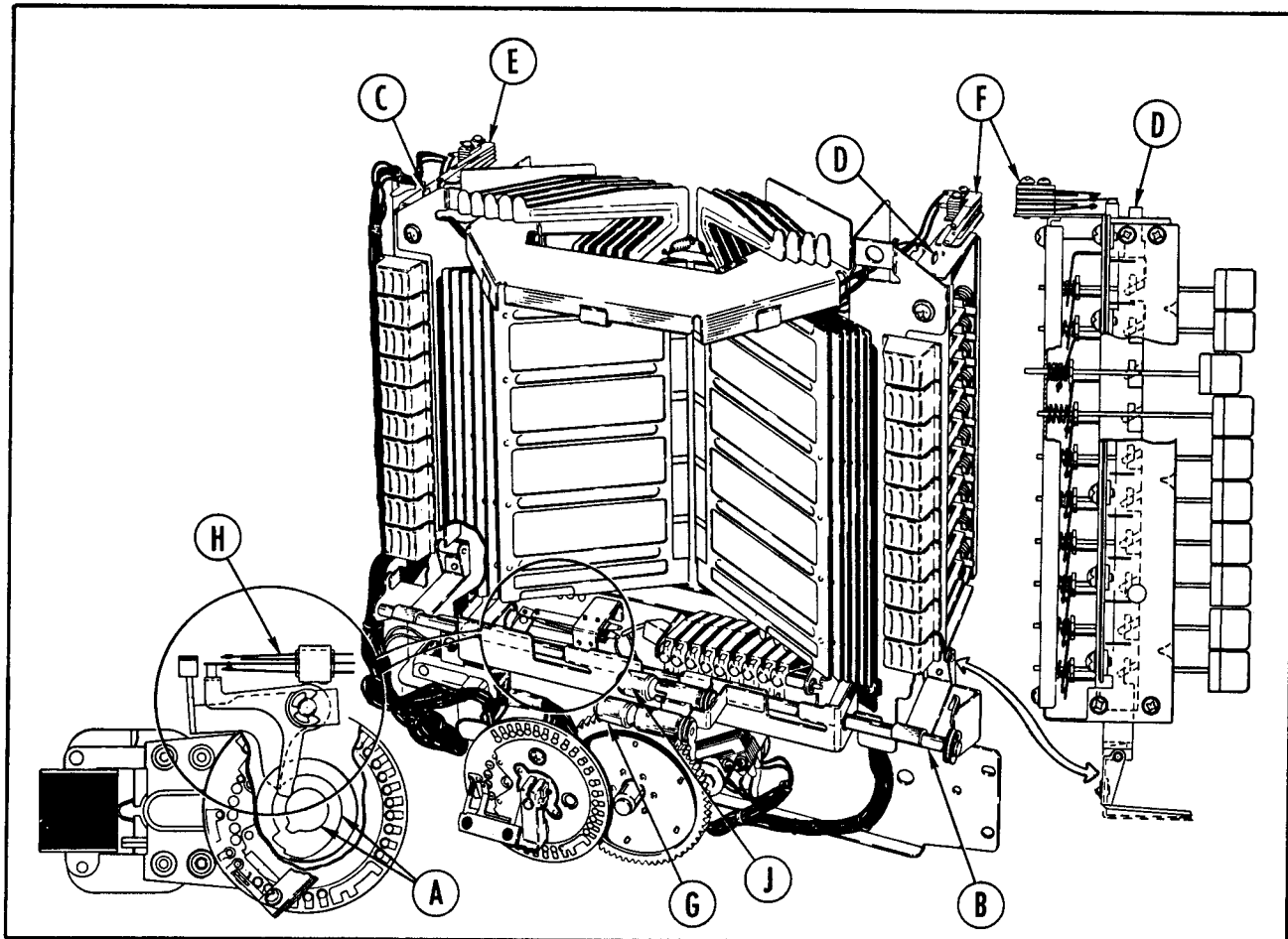

FIGURE 5.

WAIT LIGHT AND A.C. CONTROL CIRCUIT

Since the PULSE CONVERTER may receive pulses not only from the WALL BOX but also from the PULSE GENERATOR of the phonograph, provisions have been made to prevent two of these units from being operated simultaneously. This is accomplished through an AC control switch through which the "WAIT" LIGHTS (See Fig. 5(G)) are operated. The WALL BOX GEAR MOTOR must run from the home position and from the credit position through the normally closed HOME SWITCH contacts on the LEVEL STEPPING SWITCH in the PULSE CONVERTER and through one side of the transfer contacts of the MOTOR CONTROL SWITCH (H). The MOTOR CONTROL SWITCH transfers its contacts at the point where the GEAR MOTOR has run past the credit position. (This action is caused by the LEVER ASSEMBLY, one end of which follows the GEAR MOTOR CAM.) After leaving the credit position, the GEAR MOTOR will run through the other side of the MOTOR CONTROL SWITCH. This circuit is independent of the PULSE CONVERTER HOME SWITCH.

The HOME SWITCH on the PULSE CONVERTER opens its contacts as soon as the level stepper in the PULSE CONVERTER moves the first step from its home position. Thus, while the PULSE CONVERTER is operating as a result of pulses from the PULSE GENERATOR or from a WALL BOX, no other unit will move into credit position. If a coin is deposited in the PHONOGRAPH or in a WALL BOX while the PULSE CONVERTER is cycling as a result of pulses from another unit, the MAIN CREDIT SWITCH will close and the "WAIT" LIGHT will come on. It will stay on until the LETTER STEPPING SWITCH in the PULSE CONVERTER has returned to home position closing its HOME SWITCH contacts. (For PULSE GENERATOR and PULSE CONVERTER; See Service Manual - Model 900 Credit and Selection System.)

CREDIT LIGHT

The CREDIT LIGHT, (See Fig. 5, (J)) when illuminated, indicates unused credits on the CREDIT UNIT. The WIPER ARM of the WALL BOX must be in the credit position for this light to be turned on.

SLUG REJECTOR AND COIN SWITCHES

The SLUG REJECTOR and COIN SWITCHES used in the WALL BOX are identical to those in the A M I Phonograph. The rejector accepts nickels, dimes and quarters which, subsequently, pass from the exit slots onto the actuating levers of the COIN SWITCHES (See Fig. 6).

The SWITCH ASSEMBLY (See Fig. 6, (A)) has three individual switch elements, (B), (C) & (D), one for each denomination of the coins which pass through the rejector. As shipped from the factory, the 25¢ COIN SWITCH is connected to the three credit magnet (D) providing three credits for 25¢. The 5 and 10¢ COIN SWITCHES (B & C) are connected in parallel to the CREDIT MAGNET in the one credit position. A nickel diverter (E) on the SLUG REJECTOR allows every second nickel (F) which passes through the SLUG REJECTOR to actuate the COIN SWITCH. By virtue of this nickel diverter, one credit may be obtained for one dime or two nickels. When a coin actuates a particular COIN SWITCH, the related credit magnet is energized by the AC current supplied to the WALL BOX through two lines in the connecting cable.

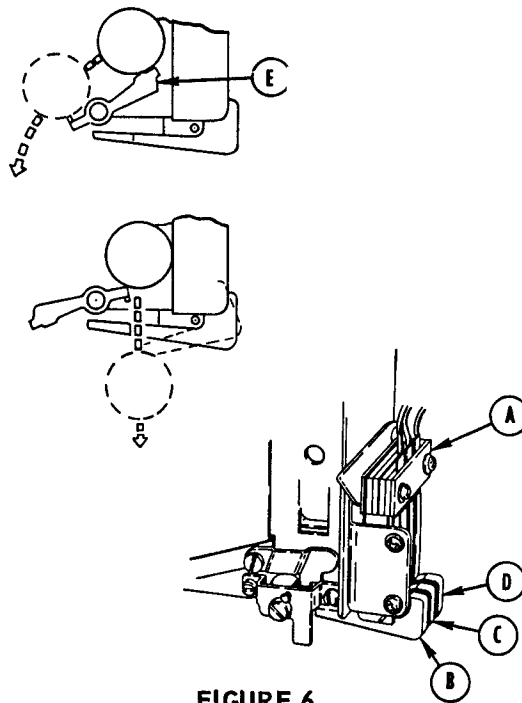

FIGURE 6.

CONNECTING WALL BOXES

As previously outlined, the WALL BOXES are connected to the phonograph through use of a four-wire cable which connects to BARRIER STRIPS located in the phonograph and in the WALL BOX. (See Fig. 7).

These BARRIER STRIP TERMINALS are labeled in each unit for convenience of connection. The wiring arrangement is such that the wire in the cable which connects to the top terminal in the phonograph must also connect to the left hand terminal in the WALL BOX. The wire which connects to the bottom terminal of the phonograph must connect to the right-hand terminal in the WALL BOX, etc.

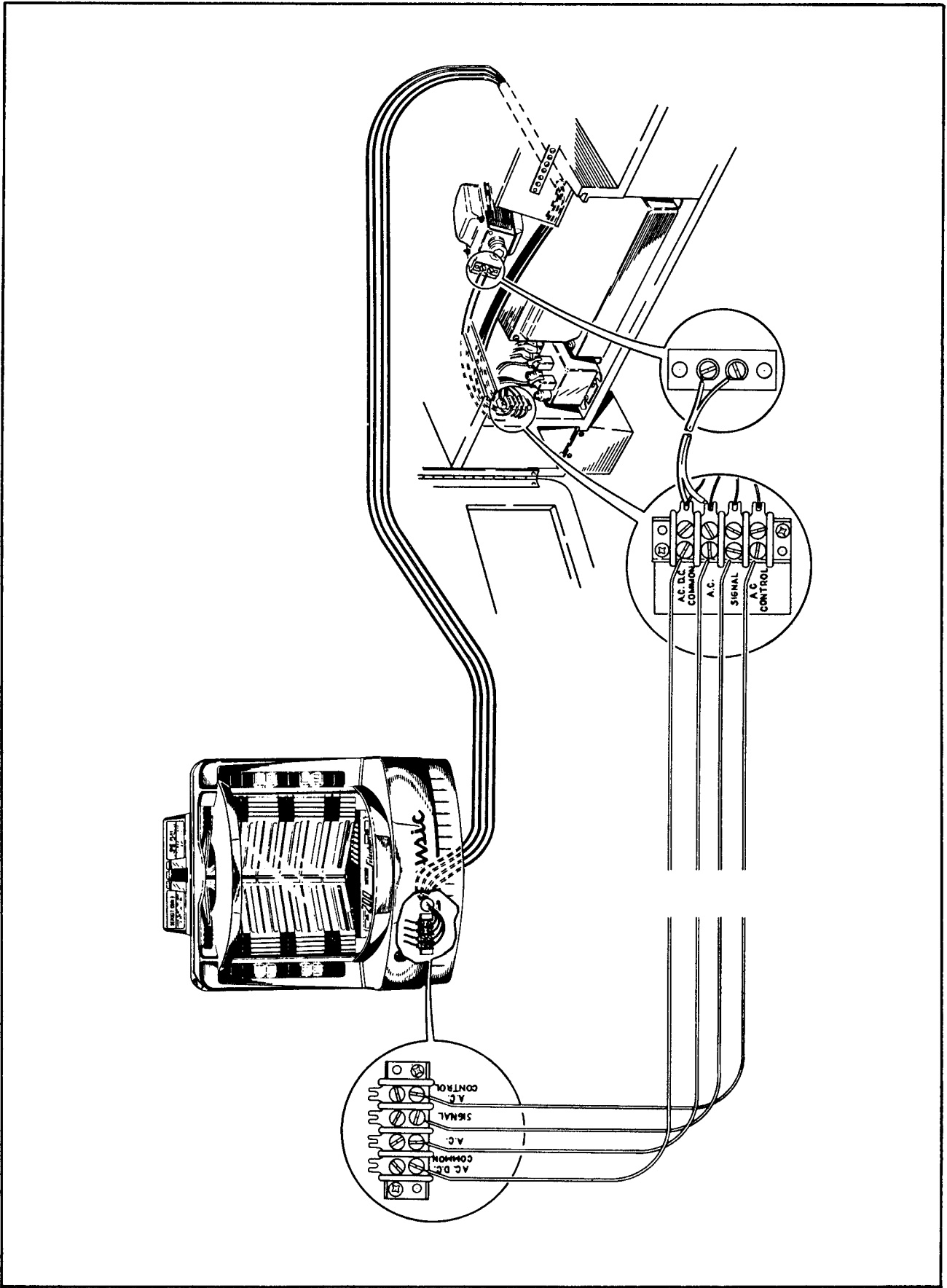

FIGURE 7.

Accessible from the rear of the phonograph is a conduit which goes through the low frequency horn and enters the lower compartment of the phonograph behind the AMPLIFIER (Fig. 7). This conduit provides a convenient means of bringing WALL BOX and SPEAKER wiring into the phonograph. Do not use this conduit for routing 110 volt circuits.

Up to eight WALL BOXES may be connected to the phonograph with one distribution line (See Fig. 8, (A)). If eight WALL BOXES are used, the length of the distribution line should not exceed 150 feet. If fewer WALL BOXES are used, the length of the line may be increased somewhat.

If more than eight WALL BOXES are to be used, they may be connected with two lines (Fig. 8, (B) or with

one line connected in a closed loop (Fig. 8, (C)). In any connection method, the AC voltage measured at the box furthest from the phonograph must be no less than 20 volts as measured with the WALL BOX cycling.

No more than 12 WALL BOXES should be connected at one time to the TRANSFORMER FUSTAT ASSEMBLY (Fig. 8, (D)) which furnishes the low voltage AC. If more than 12 WALL BOXES are to be used, a second L-235 TRANSFORMER FUSTAT ASSEMBLY must be installed in the phonograph in the location indicated. If a second L-235 TRANSFORMER FUSTAT ASSEMBLY is necessary, they should be connected in parallel. Specifically, the left hand terminal on the second TRANSFORMER FUSTAT ASSEMBLY must be connected to the left hand terminal of the one which is in the phonograph and the right hand terminals of the two must also be connected.

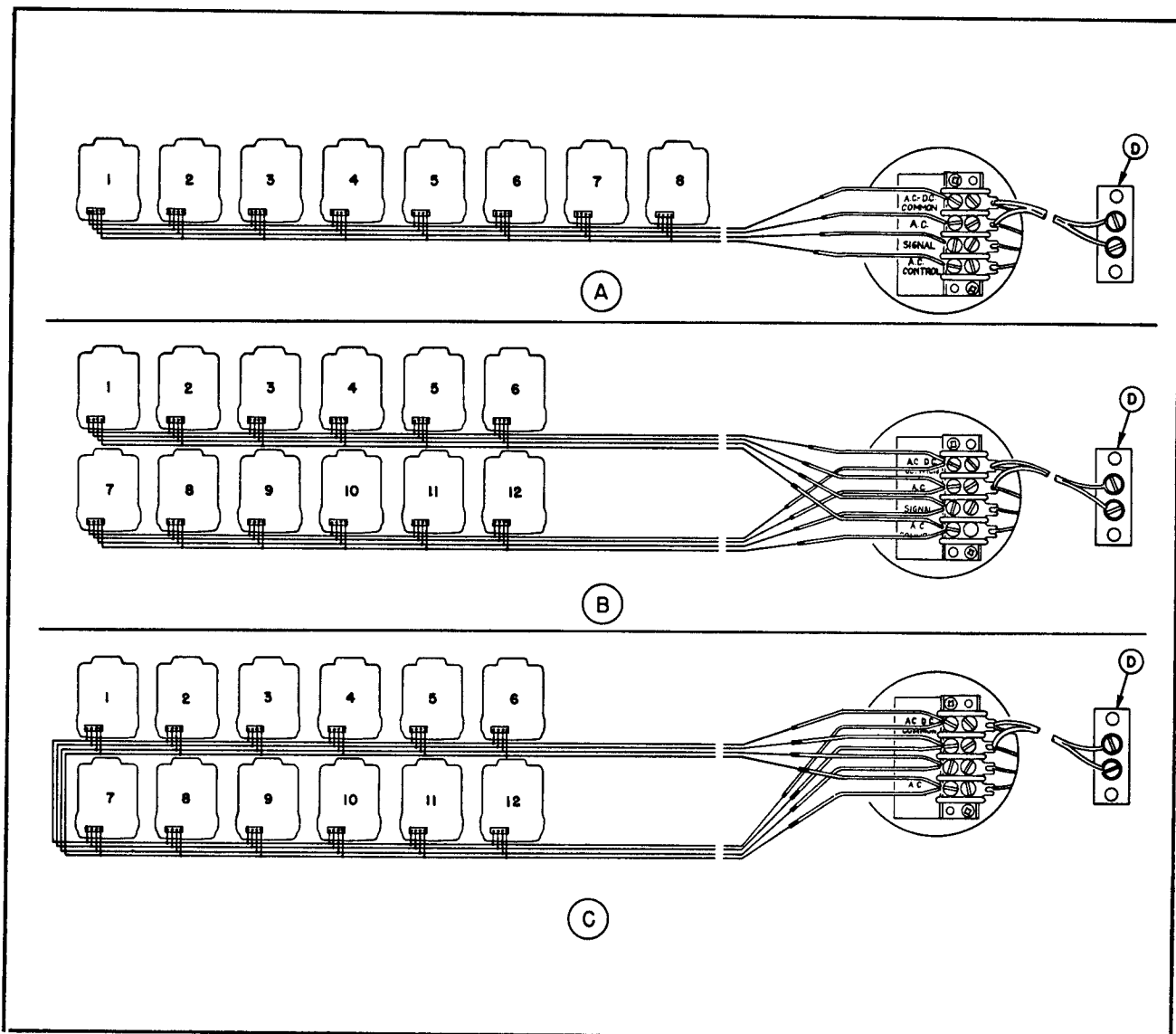

FIGURE 8.

MECHANICAL ADJUSTMENT DATA

MOTOR CONTROL SWITCH

With the WIPER ARM in such a position that the contact on the middle WIPER BLADE (See Fig. 9, (A) is making contact with the large brass disc (B) on the COMMUTATOR PLATE, the MOTOR CONTROL SWITCH should be adjusted as follows. The fiber pusher (C) on the moving blade must touch or be within .005 inch of the tab on the cam lever (D) which actuates it. At this point, the gap (E) between the pair of open contacts must be a minimum of .015 inch. The force between the closed contacts (as measured at the contacts) must be 20 grams minimum.

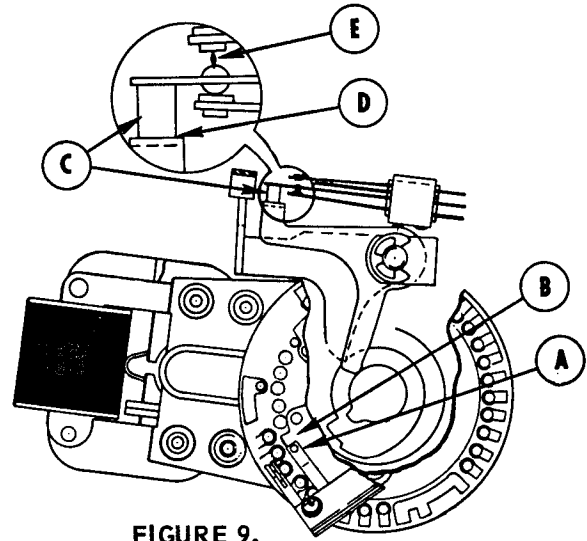

FIGURE 9.

To check the operation of the MOTOR CONTROL SWITCH, turn the WIPER ARM ASSEMBLY by hand until the pushbutton CAM FOLLOWER ARM (See Fig. 10, (A) passes the highest point on the cam and drops into the first notch. (NOTE: When turning the WIPER ARM by hand, it should be done by moving the last gear (See Fig. 10, (B) in the gear train. (Never turn this WIPER ARM by applying force against the WIPER

ARM itself.) Back the gear, at this point, to take out all play. In this position, the MOTOR CONTROL SWITCH contacts must have been transferred. The gap (C) between the open contacts at this point must be .015 minimum and the force between the closed

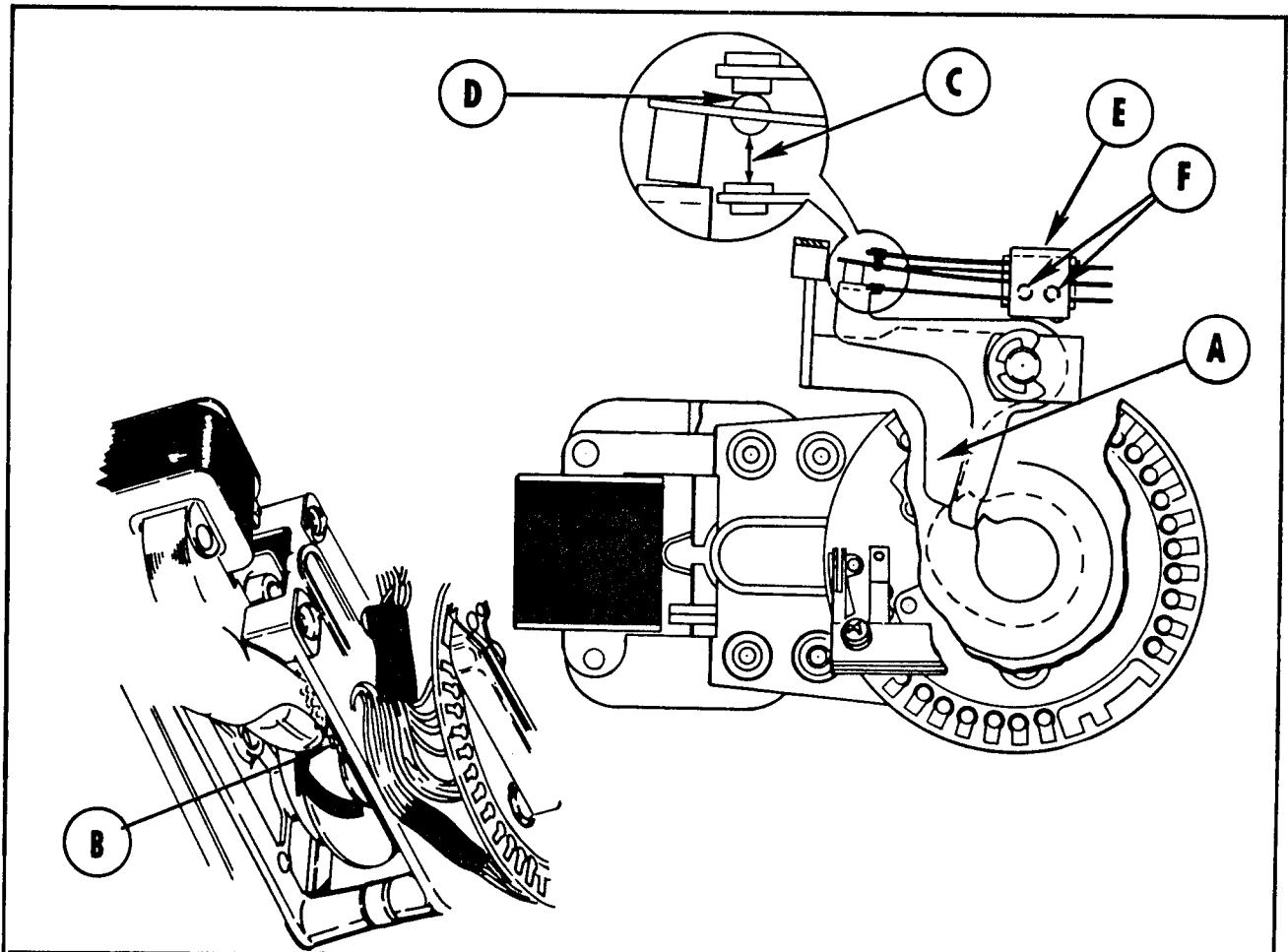

FIGURE 10.

contacts (D) must be 20 grams minimum. The MOTOR CONTROL SWITCH (E) is adjusted by shifting its position after loosening two screws (F) which hold its mounting bracket. As the switch transfers, the contacts must close before the other two open.

WIPER ARM POSITIONING

The position of the WIPER ARM with respect to the position of its DRIVE SHAFT is important. To position the WIPER ARM, turn the GEAR MOTOR so that the pushbutton CAM FOLLOWER ARM (See Fig. 11) passes the highest surface and drops into the notch following this surface. Back the GEAR MOTOR to take out all play. Then set the WIPER ARM so that the contact on the middle WIPING BLADE (A) is approximately centered between the second large home position rivet (B) and the first large credit position rivet (C). The arm should be further positioned so that the WIPER BLADE has just broken contact with home position rivet (B). The outside (bifurcated) blade (D) must be making contact with the credit position segment (E), (large segment) on the COMMUTATOR PLATE when in this described position. Tighten the WIPER ARM on the shaft (F). The arm

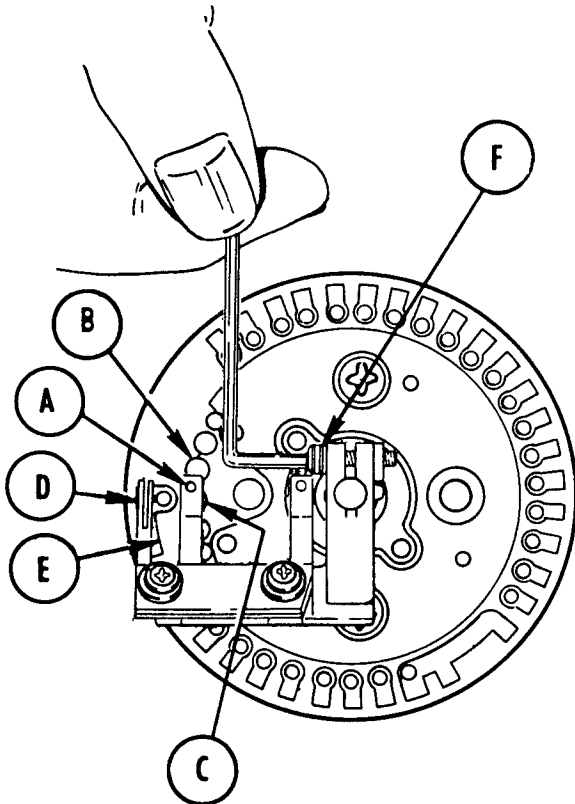

FIGURE 11.

must be adjusted so that the contacts on the inside blades exert pressures of 55 to 75 grams on the COMMUTATOR PLATE. The force of each half of the bifurcated blade against the COMMUTATOR PLATE must be 10 to 20 grams.

PUSHBUTTON BANKS

With the WALL BOX WIPER ARM in credit position (see Fig. 12, (A) (the pushbutton CAM FOLLOWER ARM in the first notch of the cam (B), each pusher (C) on the SHAFT AND LEVER ASSEMBLY must support its LATCH BAR at such a height that a minimum of .010 inch interference is obtained between the latch bar and the pushbutton shaft, (Fig. 12, (G) when a pushbutton is latched in. The pushers must be set low enough to accomplish this, but high enough to unlatch any pushbutton as the WALL BOX operates. With a pushbutton latched in, the INTERLOCKING BAR, (D) must be raised high enough to prevent any other button from being depressed.

PUSHBUTTON CONTACTS AND STARTING SWITCH ADJUSTMENTS

Two STARTING SWITCHES are located at the top of the two PUSHBUTTON BANKS (See Fig. 5, (E & F). They are individually actuated by LATCH BARS in their respective pushbutton banks. With no pushbutton latched in, the normally open pair of contacts (See Fig. 12, (E) on the starting switch must have a minimum gap of .020 inch. The contact pressure on the normally closed bottom contacts (F) must be 10 grams minimum. With any pushbutton latched in, the top contacts must be closed and the contact pressure must be 10 grams minimum. The bottom contacts must be opened with a minimum gap of .010 inch.

Individual contacts on each pushbutton must be opened by .020 inch minimum with their corresponding button latched in. With no pushbuttons depressed, all individual selection contacts must be closed with contact pressures of 40 to 90 grams.

MOUNTING THE WQ-200 WALL BOX

The AMI R-167 BAR GRIP is provided as a convenient method of mounting the WQ-200 WALL BOX on any bar or counter top. Through the use of this BAR GRIP, the WALL BOX may be mounted on any counter top without drilling mounting holes in the counter top to which it is being attached. The BAR GRIP clamps to the counter top and the WALL BOX is then attached to the BAR GRIP through use of mounting holes in the rear housing of the WALL BOX. If the box is to be mounted on plaster or masonry wall surfaces, it may be advisable to first attach a plywood panel of the same shape and size as the rear of the WALL BOX to the wall by means of anchor bolts and then attach the WALL BOX to this plywood panel.

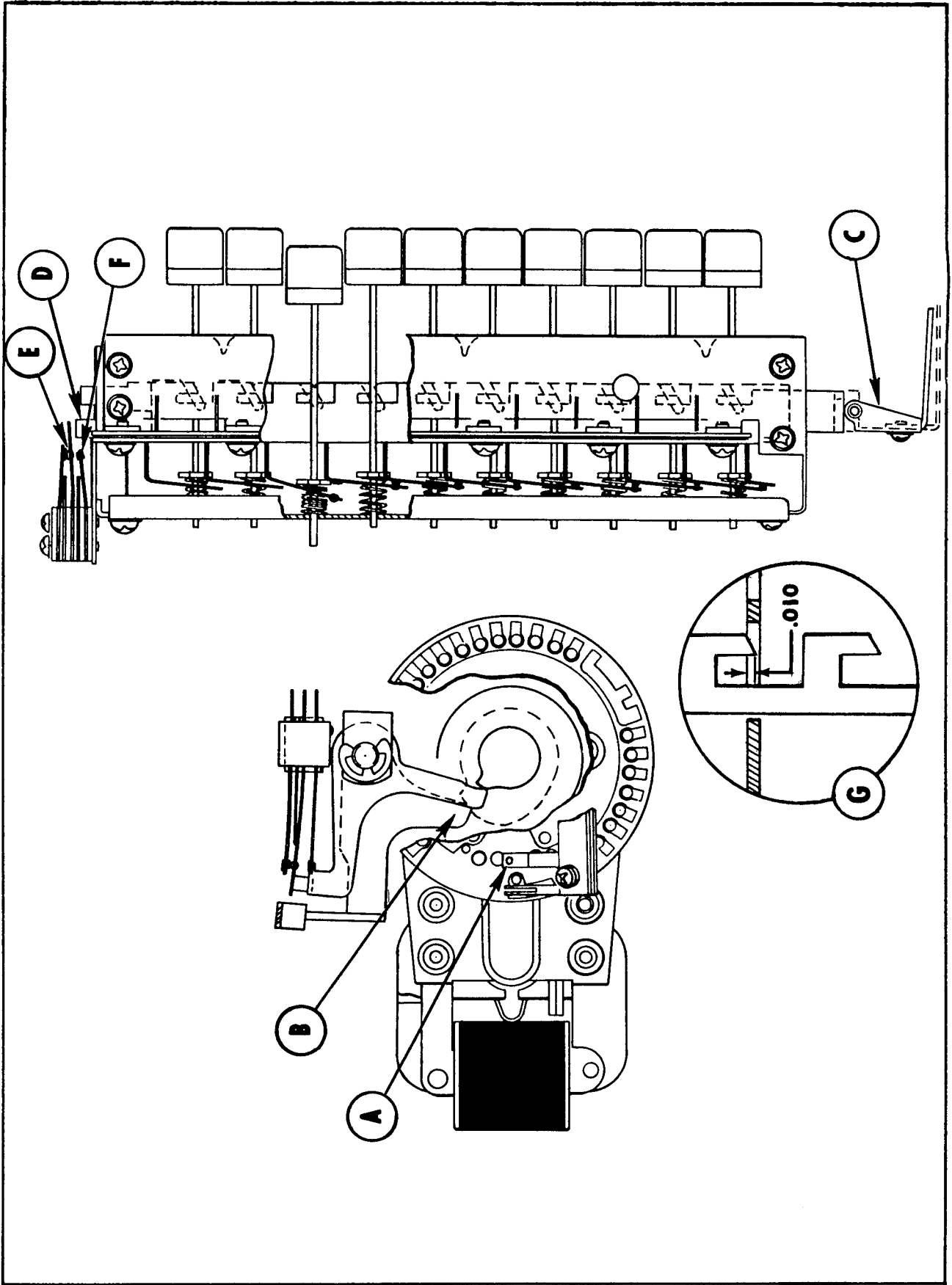
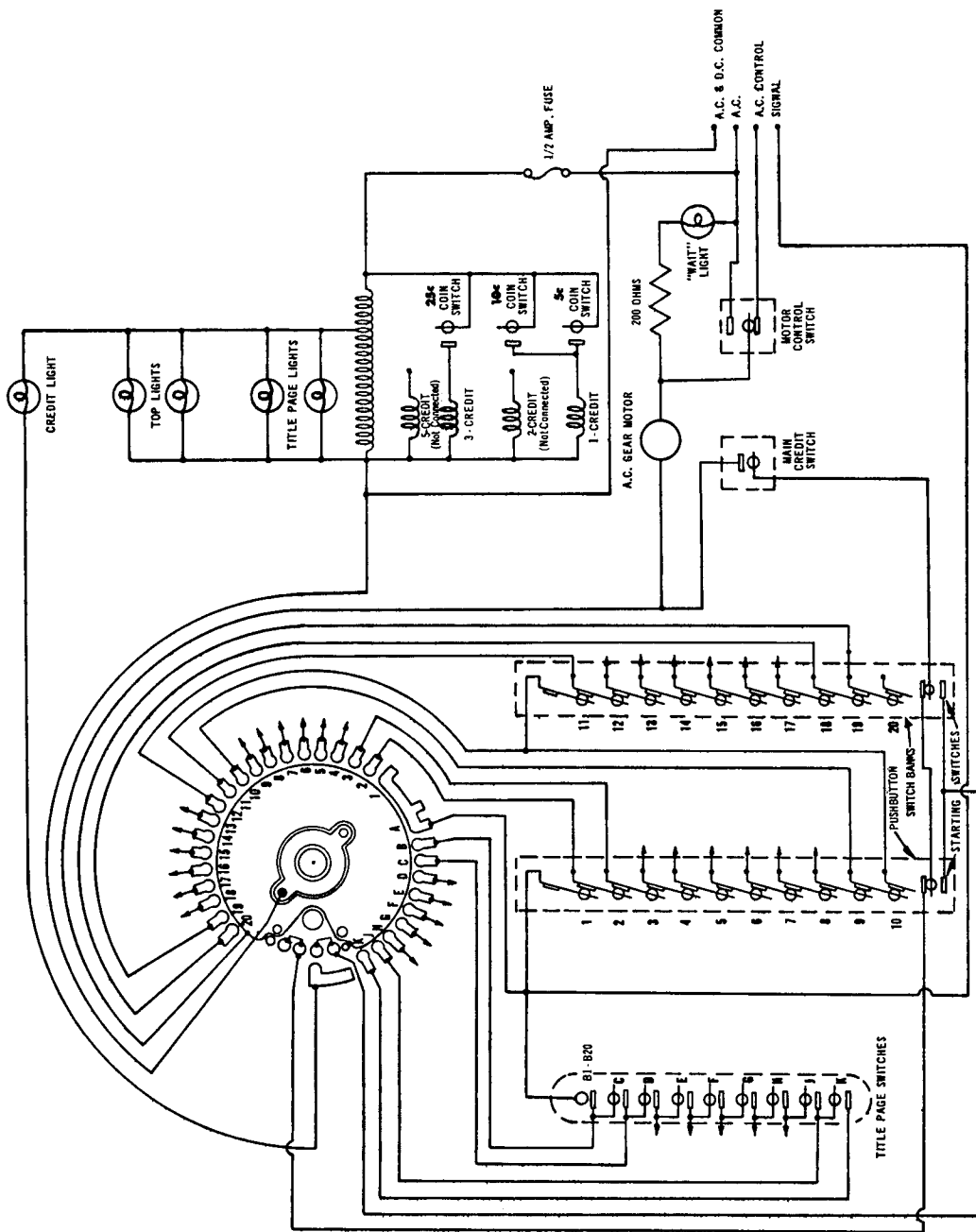

FIGURE 12.



WQ-200 WALL BOX SCHEMATIC DIAGRAM

AMI *Incorporated*

**1500 UNION AVENUE, S.E.
GRAND RAPIDS 2, MICHIGAN**