

SEEBURG

STEREO CONSOLETTA, Type SC1

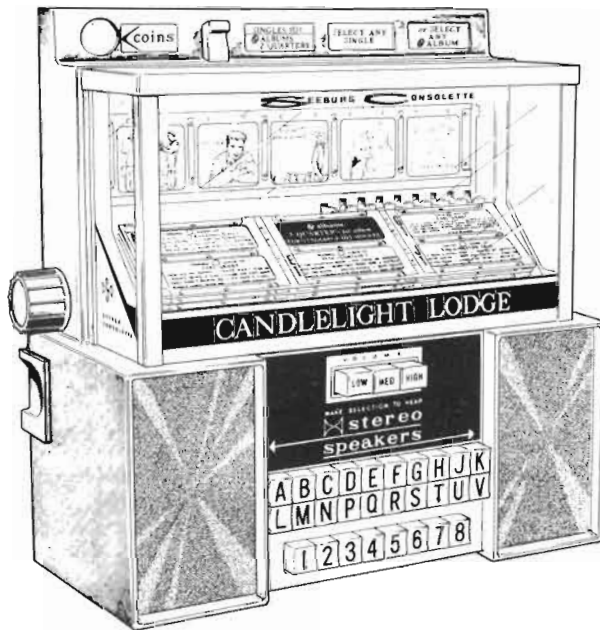

Figure 1. Exterior View.

The Seeburg Stereo Console, Type SC1, is a unit of the Seeburg wired remote control system designed for the remote choice of "Album" or "Single" play selections in the Select-O-Matic phonograph. The Console is equipped with a pair of speakers - Right Channel and Left Channel - which provide for localized listening to selections. Speaker volume may be controlled at the Console by push buttons marked LOW, MEDIUM and HIGH. When a selection is made at the Console, circuits are completed through the phonograph which permit listening to the program through the Console stereo speakers. The speakers continue operation until the phonograph mechanism comes to rest and are then silent until a selection is again made at the Console.

The Console operates in conjunction with the selection and audio systems in the LPC model phonograph. The Console is connected to the phonograph with a 10-conductor color-coded cable.

The pricing structure of the Stereo Console, Type SC1, is initially set up at the factory: one album for 2 quarters, three single plays for one quarter, or one play for a dime or two nickels.

The Console is equipped with a Type APU10-56, Album Pricing Unit, which provides extreme flexibility in setting up different pricing combinations as detailed on pages 6 & 7. The slug rejector is designed to accept quarters, dimes and nickels. Each coin operates a coin switch to establish credit for the selection of a play at the Console. At the same time, the credit unit in the Console transmits the total credits accepted to the Type IT1R-56, Income Totalizer in the phonograph which indicates total cash deposited.

When the phonograph main switch is turned on, credit lights in the Console go on immediately after minimum credit has been established, i.e., two nickels or a dime have been deposited. The credit lights stay on as long as there remain unspent credits.

The Console mechanism operates at 24 volts A.C., 60 cycles. Power is supplied by the RCSU4, Remote Control Stepper Unit, for up to 6 Stereo Consoles. If the installation requires more than 6 Consoles, an Auxiliary Power Supply, Type RPS6-56, must be used for each additional group of 6 Consoles.

The black and white wires of the interconnecting cable carry power to the lights and motor. The blue and black wires comprise a selection circuit to provide remote control of the selection system operation in the phonograph. The brown, red, and orange wires are for transmittal of coin deposit information to the income totalizer in the phonograph and their terminal board is covered and sealed as shown in *Figure 2*. The balance of wires in the cable are for audio and control of the stereo speakers in the Console.

Bar Bracket Assembly, Seeburg Part No. 500225, is available for rigidly mounting the Console on bars, counters and tables.

The Stereo Console has been thoroughly tested before leaving the factory. Unless damaged in shipment, no adjustments to the Console are necessary.

left hand speaker be disconnected and removed from the Consolette to prevent damage to the speaker during wiring. To wire the Consolette, proceed as follows: (See Figures 3 and 4)

1. Remove the cash box. Disconnect and remove left speaker. Remove the bottom hole cover and the cable channel. Remove the terminal board cover from the left hand terminal board.

NOTE: Later models have the above underlined items packaged in plastic bag inside of cash box.

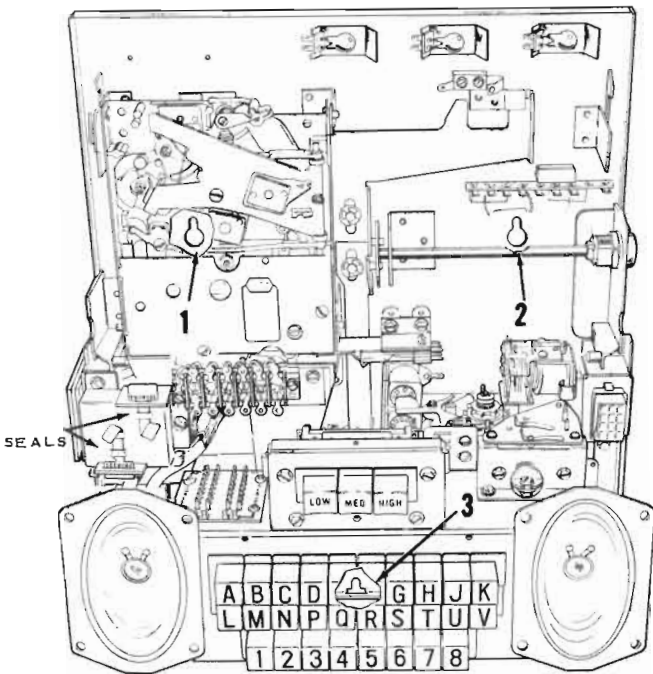

Figure 2. Interior View - Mounting and Seals..

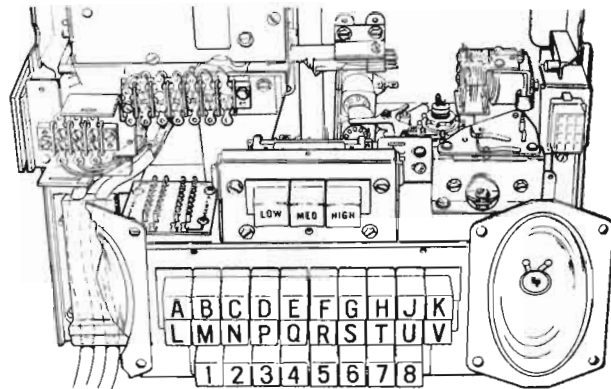

Figure 3. Terminal Boards - Wiring Connections.

STEREO CONSOLETTTE INSTALLATION

Mounting the Consolette

There are three holes in the back plate for mounting, identified 1, 2 and 3 in Figure 2. The two upper holes are slotted for fitting over screws already set in the wall at the proper points. The lower hole is for rigidly mounting the Consolette by means of a screw, after it has been hung in place.

If the mounting place on the wall is uneven, the Consolette mounting plate should be shimmed with cardboard or wood before tightening the three mounting screws. Tightening the mounting screws on an uneven wall will bend the mounting plate, which may seriously affect the operation of the Consolette and may cause the cover and lock to bind.

To gain access to the mounting holes in the Consolette's back plate, proceed as follows:

1. Unlock the Consolette and slide off the housing.
2. Remove the program holder by raising the two latches at the top of the program holder and lifting it up and out of the Consolette.
3. Remove the slug rejector by lifting it up and out.

Wiring the Consolette

Use 10-conductor interconnecting cable, Seeburg Part No. 507503, to connect the Consolette to the phonograph. This cable can be purchased in bulk and cut to the correct length for each installation. It is recommended that the

2. Feed the interconnecting cable, Seeburg Part No. 507503, through the bottom hole cover and solder on spade lugs, Part No. 940592. Feed the brown, red and orange leads to the lower terminals on the left hand terminal board and carefully dress leads through slot in the mounting bracket so that leads will not be shorted when terminal board cover is installed.

CAUTION: Push spade lugs all the way on to screw to insure clearance when cover is installed.

Connect each lead to the color coded terminal that matches the color of the lead.

3. Feed the black, white, grey, violet, blue, green and yellow leads behind the right hand terminal board and up around the board to the top terminals. Limit wire dressing slack to avoid interference with the bottom of slug rejector to insure proper operation. Connect each lead to the color coded terminal that matches the color of the lead.

CAUTION: Color code matching must be strictly observed.

4. Replace the cover on the left hand terminal board; secure with two screws. Install one of the seals from the lower left side of the terminal board cover so that the serial number is right reading and fold the tab down at the score mark. Install the other seal from the upper right side of the terminal board cover and fold the tab up at the score mark. (See Figure 2).

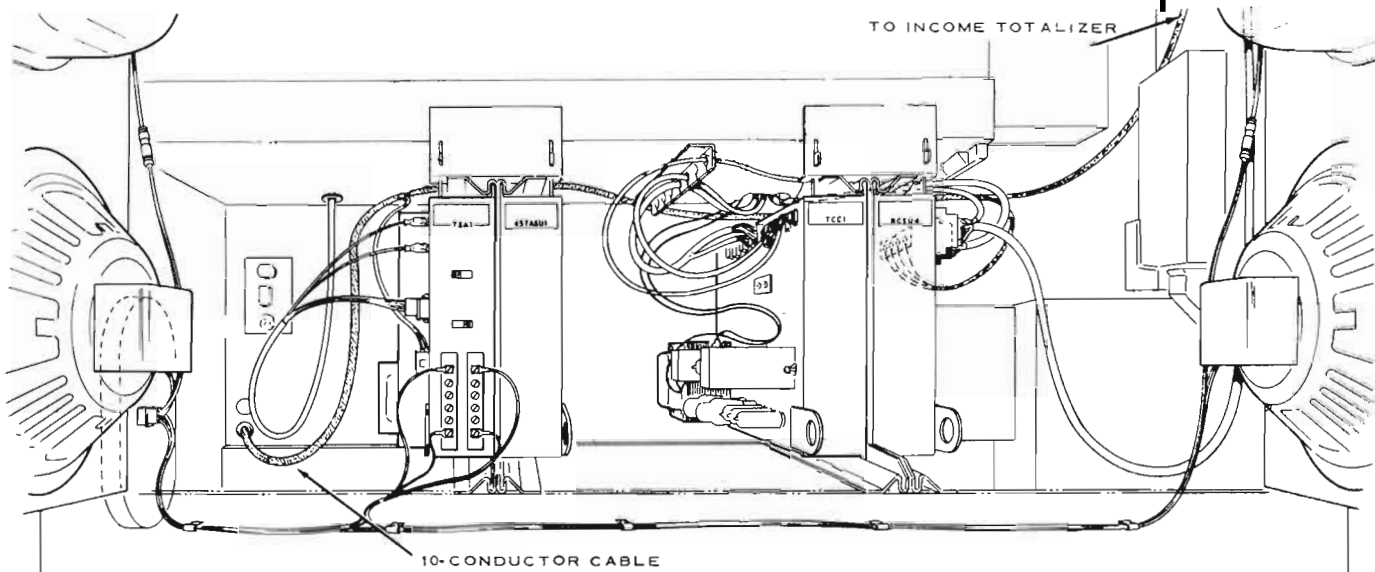

Figure 4. Phonograph Wiring Diagram – Cable Installation in Phonograph.

5. Install the cable channel over the cable and secure it with the top two screws. Position the bottom hole cover and secure both the bottom hole cover and the cable channel with the two lower screws.
6. Position the left hand speaker; secure with two screws from above the mounting bracket. Reconnect the left hand speaker by pushing-on its taper tabs. Note that tabs are different in size and must match connector on speaker to insure proper phasing.
7. Install the cash box, slug rejector and program holder.

Phonograph Wiring

Feed the 10-conductor cable through the hole (located in the lower left hand corner when facing the phonograph). Remove the Masonite plate covering the hole and feed the cable through the grommet. Dress the cable in the phonograph as shown in *Figure 4*.

Referring to system wiring diagram, *Figure 6*, connect the violet, blue, white and black leads of the 10-conductor cable to the matching color coded terminals on the terminal board in the Remote Control Stepper Unit, Type RCSU4. Solder one spade lug, Seeburg Part No. 940592 to each of these leads. Be sure the colors of the leads match the colors called for on the terminal board.

Connect the yellow, grey and green leads to the terminal block on the Transistorized Stereo Amplifier, Type TSA1. Strip the end of each lead,

slip it in the proper color coded hole and tighten the terminal screw to secure the lead as shown in *Figures 5a and 5b*.

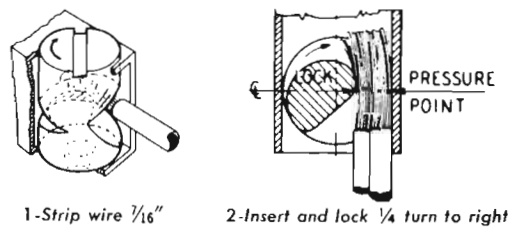

1-Strip wire 1/16" 2-Insert and lock 1/4 turn to right
Figure 5a. Stripping and Locking Wire.

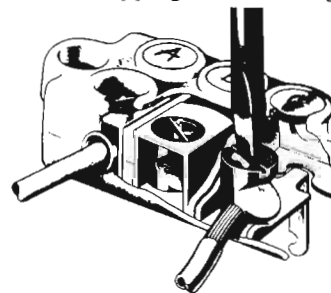

Figure 5b. Perspective Showing Application.

Connect the brown, red and orange leads to the terminal strip on the Income Totalizer, Type IT1R-56. Solder one spade lug, Part No. 940592, to each of these leads and connect them to the proper color coded terminals.

NOTE: The phonograph is capable of supplying power for six Stereo Consolettes. If the installation requires more than six Consolettes, an Auxiliary Power Supply, Type No. RPS6-56, must be added to the Remote Control Stepper Unit for each additional six Consolettes. Connect the remaining leads from these Consolettes in the same way as the first six Consolettes.

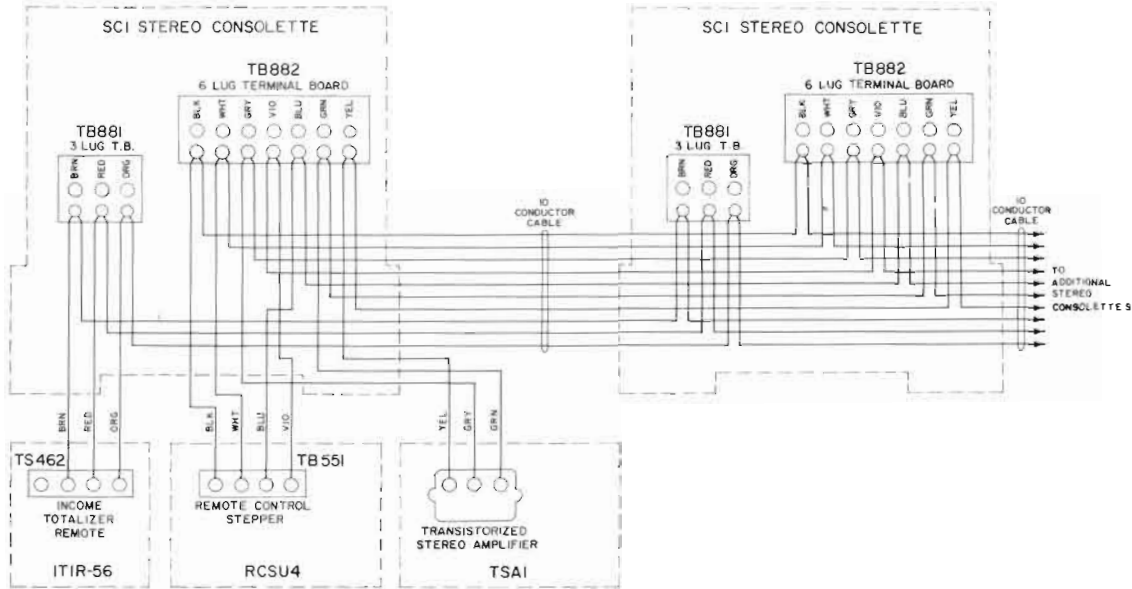

Figure 6. System Wiring Diagram.

Phonograph Wiring

(Used on LPC1R Model Phonographs above Serial No. 112980 (approximately))

On later model phonographs, a 10-Station Cam Action Terminal Block is used for connecting the 10-conductor cable to the phonograph as shown in Figure 7. Internal cabling from the Terminal Block to the various electronic components in the phonograph is factory installed.

Stripping and locking of 10-conductor cable wire is the same as illustrated in Figures 5a and 5b. A system wiring diagram using the 10-Station Cam Action Terminal Block is shown in Figure 8.

NOTE: For application of Cover Seal, refer to section titled "Stereo Consolette Installation"; page 2, step 4.

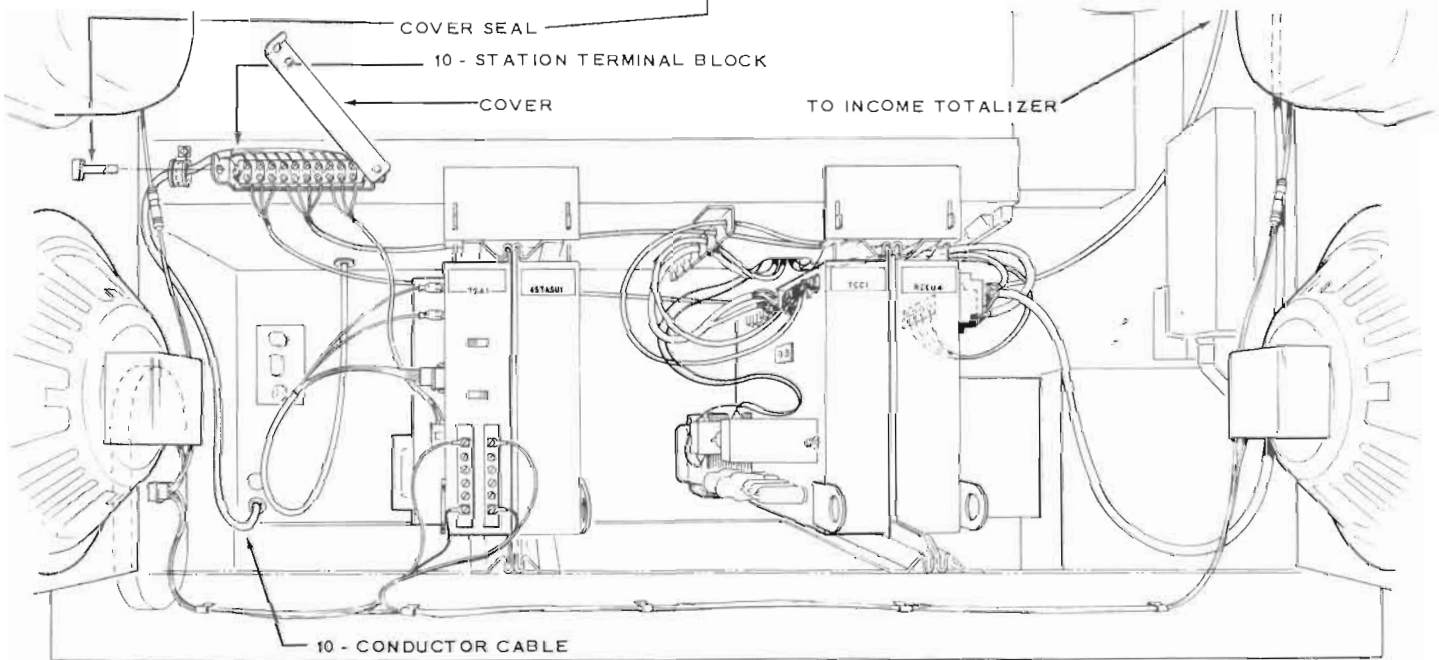

Figure 7. Phonograph Wiring Diagram - Cable Installation in Phonograph.

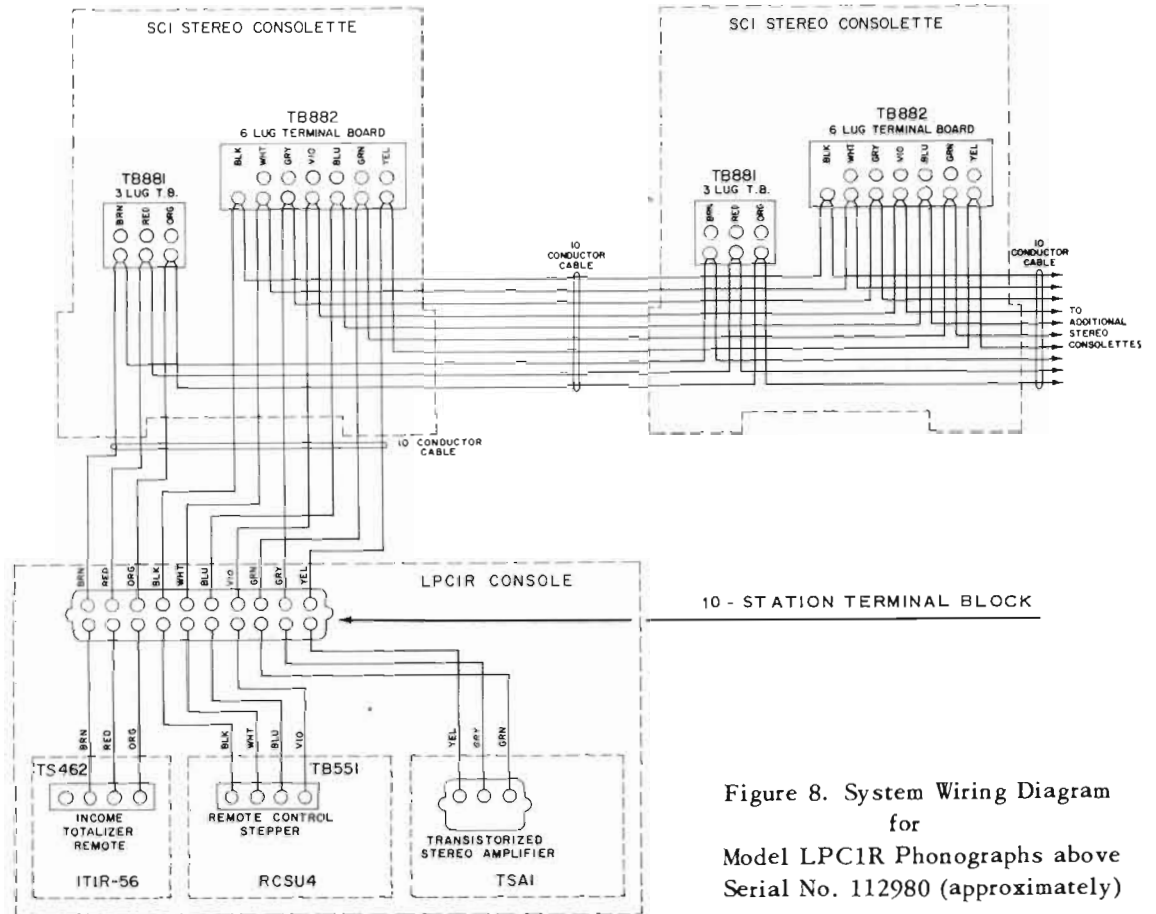

Figure 8. System Wiring Diagram for Model LPC1R Phonographs above Serial No. 112980 (approximately)

PROGRAM HOLDER INSTALLATION

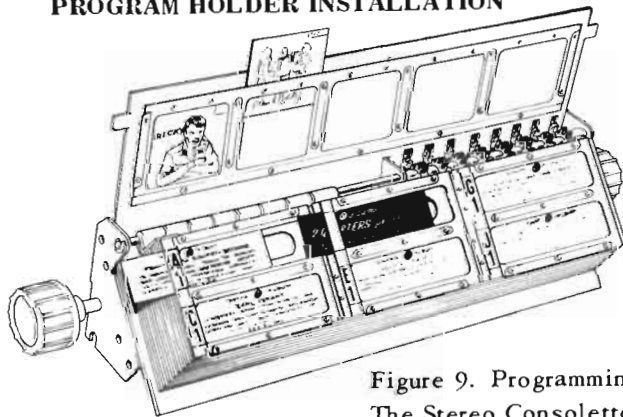

Figure 9. Programming The Stereo Consolette.

Lithographed LP miniature facsimiles of the album record jacket are supplied for the Consolette in the Albums of the Month Record Package. Unlatch and remove the program holder from Consolette. Slide five album facsimiles in the upper plate of the program holder from the top. Slide five album facsimiles in the lower plate of the program holder from the bottom.

Slide five title strips in each side of the eight program leaves, slide each strip in from the left side of the program leaf. Be sure the "letter-number" codes on each title in the Consolette

match the "letter-number" code for that title in the phonograph. Slide the album pricing card or single pricing card in the upper center slot on every program leaf, Figure 9.

Install the program holder in the Consolette and secure firmly with two latches.

PERSONALIZED LOCATION DISPLAY INSTALLATION

The Stereo Consolette features a display panel which may be used to identify the location. The display holder is secured inside the housing by two spring clips which hold it against the glass. Lift the display holder upward to remove. Hold spring clips open if necessary (see Figure 10).

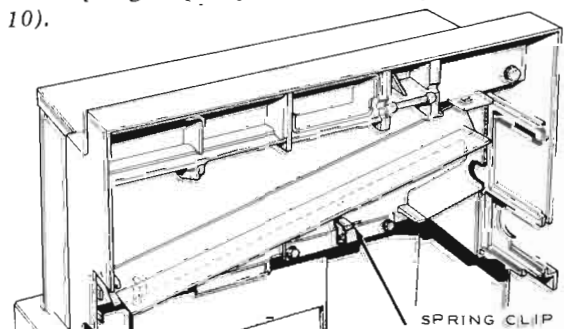

Figure 10. Removing Display Holder.

Letters, numbers and spacers, etc. required to make up the sign are available from your Seeburg distributor under Part No. 509088, Type RACK-1, Remote Alphabet Case Kit.

Slide letters into position, making certain that all characters are close together, on the same plane and that the completed display is centered (see Figure 11).

When the display holder is loaded, press it into the spring clips inside the housing. Install the housing on the Consolette and secure with lock.

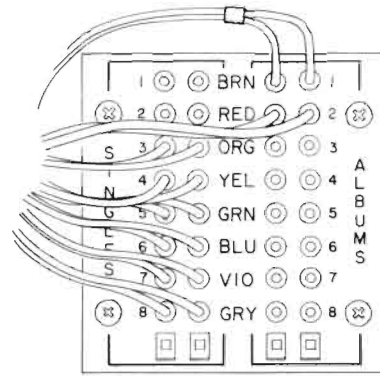

Figure 12. Pricing Terminal Board.

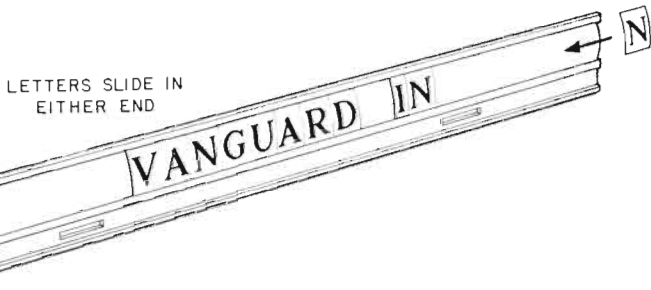

Figure 11. Letter Installation.

PROGRAMMING THE STEREO CONSOLETTTE

When the Consolette is shipped, the pricing mechanism is permanently wired for "Albums" in group 1 and 2. "Singles" are set up in groups 3 through 8. Albums are priced to play for 2 quarters. Single records are priced to play for ten cents or three for a quarter.

In order to change the album grouping or to provide additional groups of albums, shift the two (2) leads which correspond to the particular group to be changed, from the "Singles" terminals to the "Albums" terminals, or vice versa to change from "Albums" to "Singles" grouping as shown in Figure 12. It is recommended that "Albums" grouping changes be made in numerical order. Number Strip Cards in the program holder should be changed at the time when "Album" grouping is changed. The cards are available from your Seeburg Distributor and are listed below.

PART NO.	ALBUM GROUPING
50770 1	NUMBER STRIP CARD A3
507702	NUMBER STRIP CARD A4
507703	NUMBER STRIP CARD A5
507704	NUMBER STRIP CARD A6
507705	NUMBER STRIP CARD A7
507706	NUMBER STRIP CARD A8

When pricing combinations are to be modified, change the Pricing Window in the top of the Consolette housing and change the Pricing Cards in the program holders.

Number	PRICING WINDOW PART NUMBER	SINGLE PRICING CARD PART NUMBER	ALBUM PRICING CARD PART NUMBER
1	*507457	*507508	*507506
2	507660	507508	507686
3	507457	507683	507506
4	507660	507683	507686
5	50766 1	507684	507686
6	507457	507685	507506
7	507660	507685	507686

* SUPPLIED WITH STEREO CONSOLETTTE.

Figure 13. Pricing Windows and Cards.

The table, Figure 13, lists pricing windows and pricing cards which correspond to pricing windows for seven (7) different pricing combinations numbered (1) through (7) and listed in Figure 18, Album Pricing Unit Adjustment Chart. Items identified by an asterisk are supplied with the Consolette. All others are available from your Seeburg distributor.

For complete Album Programming of the Stereo Consolette, refer to Album Programming Instruction Sheet, Part No. 507715. It further illustrates and details requirements involving the adjustments of the APU10 and associated application of pricing cards and windows.

Refer to the phonograph instruction manual for the procedure for making corresponding pricing changes in the phonograph. Be sure the phonograph and each Consolette are set to play the same selection with the choice of the same "letter-number" group.

Pricing Window Kit (Quarter Only), Part No. 509150, makes it possible to set up the slug rejector for quarter play only. Nickels and dimes deposited are automatically returned. A new Pricing Window and "Singles" Pricing Card is included.

PRICING CHANGE ADJUSTMENTS

The Album Pricing Unit, Type APU10-56 is designed for use in the Stereo Console. It exemplifies high versatility in credit units and is capable of extreme flexibility in setting up pricing combinations and Album Programming. A chart, *Figure 18*, condenses information regarding the setup requirements for seven (7) popular pricing combinations.

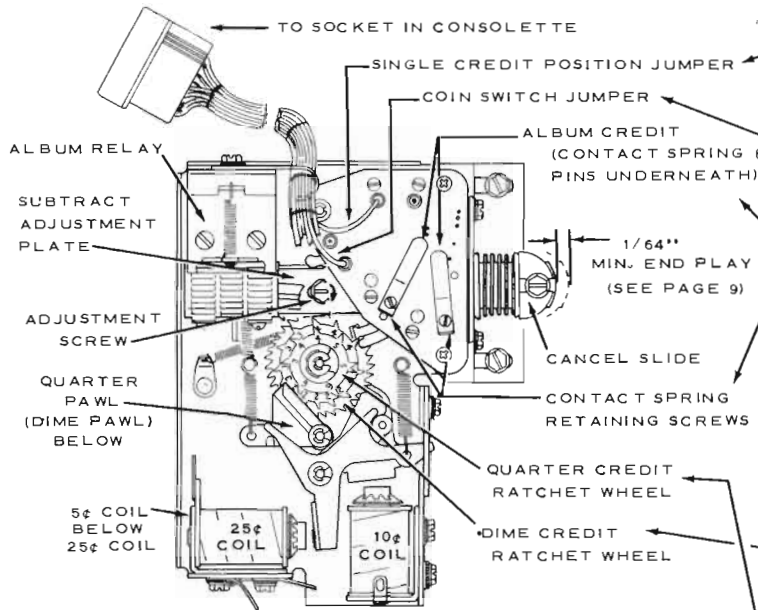

Figure 14. Album Pricing Unit, APU10-56

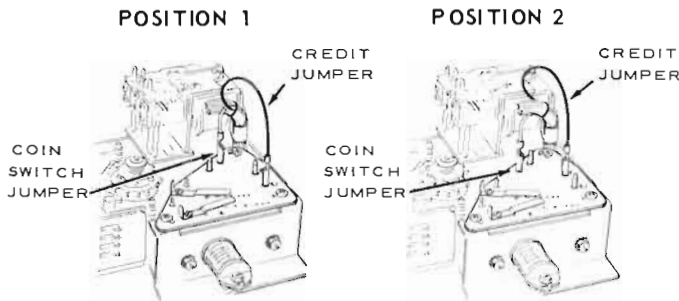

Figure 15. Coin Switch and Credit Jumpers.

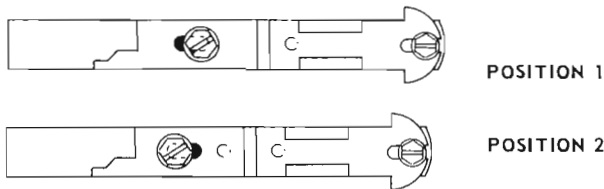

Figure 16. Subtract Plate Positions.

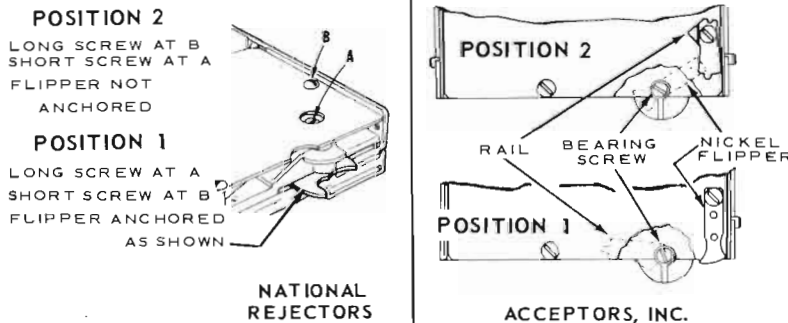

Figure 17. Slug Rejector Adjustment.

Adjusting the Pricing Unit

1. Connect the Single Credit Position Jumper (grey) as required, see *Figure 15*.
2. Connect the Coin Switch Jumper (red-white) as required, see *Figure 15*.
3. Remove the contact spring retaining screws and place the contact pins in their required positions. Replace contact springs and tighten in position.
4. Adjust the Credit Ratchet Wheels to the required settings as follows:
 - a. Turn the ratchet wheel assembly to the maximum clockwise position. This places all three ratchet wheels in zero credit position.
 - b. Lift and turn the 10¢ ratchet wheel (the middle wheel) to the number shown in the Pricing Chart (*Figure 18*). The peak of the tooth on the 10¢ add pawl should be in line with the peak of the first number in the group of credit per coin indicating numbers (when counting clockwise) on the ratchet wheel.
 - c. With the 10¢ ratchet wheel adjusted, lift and turn the 25¢ ratchet wheel to the number shown in the pricing chart. The peak of the tooth on the 25¢ add pawl should be in line with the peak of the first number in the group of credit per coin indicating numbers (when counting clockwise) on the ratchet wheel.

5. To adjust the Subtract Adjustment Plate, first loosen the adjustment screw. The screw can be reached when the Cancel Slide is pushed in. Adjust the plate to Position 1 or Position 2 as required, see *Figure 16*. Tighten screw.

Adjusting the Slug Rejector

Remove the slug rejector from the Console and set the flipper to Position 1 or Position 2 as required. See *Figure 17*.

NUMBERS	PRICING WINDOW, SINGLE PRICING & ALBUM PRICING INFORMATION	ALBUM CREDIT CONTACT PIN POSITIONS	CREDIT RATCHET WHEEL POSITIONS		SUBTRACT ADJUSTMENT PLATE POSITION	SINGLE CREDIT JUMPER POSITION	COIN SWITCH JUMPER POSITION	SLUG REJECTOR
			DIMES	QUARTERS				
1	singles: 10¢ per selection QUARTER 3 selections albums: 2 QUARTERS				POSITION 2	POSITION 2	POSITION 2	POSITION 1
2	singles: 10¢ per selection QUARTER 3 selections albums: 1 QUARTER				POSITION 2	POSITION 2	POSITION 2	POSITION 1
3	singles: 10¢ per selection QUARTER 5 selections albums: 2 QUARTERS		NOT USED		POSITION 1	POSITION 1	POSITION 1	POSITION 2
4	singles: 10¢ per selection QUARTER 5 selections albums: 1 QUARTER		NOT USED		POSITION 1	POSITION 1	POSITION 1	POSITION 2
5	singles: 5¢ per selection QUARTER 6 selections albums: 1 QUARTER				POSITION 1	POSITION 1	POSITION 2	POSITION 1
6	singles: 10¢ per selection QUARTER 4 selections albums: 2 QUARTERS		NOT USED		POSITION 1	POSITION 1	POSITION 1	POSITION 2
7	singles: 10¢ per selection QUARTER 4 selections albums: 1 QUARTER		NOT USED		POSITION 1	POSITION 1	POSITION 1	POSITION 2

Figure 18. Album Pricing Unit Adjustment Chart.

PHONOGRAPH AUDIO POWER CONSIDERATION

In locations where the Stereo Console has been installed close to the phonograph, adjustments should be made at the amplifier to reduce phonograph speaker power. Excessive output from the phonograph speakers will override and negate the sound emanating from the stereo speakers in the Console. As low as a 2-

watt phonograph speaker setting may be required, however, the total amplifier load should not be less than 6 watts.

Refer to the LPC Installation Manual, Part No. 487390 for typical system installation using Stereo Consolettes. Note that total amplifier loading must not exceed 25 watts per channel.

REMOVAL & INSTALLATION OF APU10

TO REMOVE APU10

1. Rotate Contact Wiper Arm on Motor Assembly to position shown in Fig. 1.
2. Disconnect the 12 contact plug.
3. Remove mounting screws. (Fig. 4).
4. Pull unit forward until free of locating pins on SC1 backplate, lift on right side turning right side outward while lifting.
CAUTION do not touch Coin Switch!



Fig. 1.

TO INSTALL APU10

1. Rotate Contact Wiper Arm to position shown in Fig. 1.
2. Pull Return Lever on Motor Assembly away from SC1 Back Plate. (Fig. 3).
3. Reverse step 4 removal procedure. Be sure Pawl Pin on Cancel Slide is between Return Lever and SC1 Back Plate. (Fig. 3).
4. Start the mounting screws. Make sure to use flatwashers if they were used previously.
5. Rotate Contact Wiper Arm to Credit Position. (Fig 2).
6. To get proper Cancel Slide "end play" clearance of $\frac{1}{32} \pm \frac{1}{64}$ slide APU10 backward or forward. This is IMPORTANT for unit to subtract properly. (Fig 4).
7. Tighten screws, recheck "end play", and insert plug.

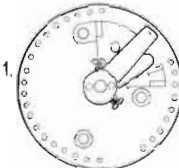

Fig. 2.

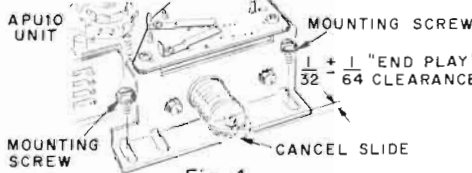

Fig. 4.

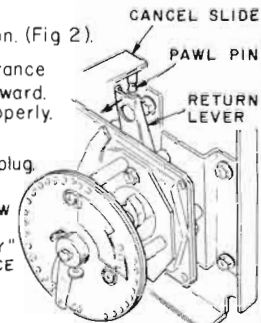

Fig. 3.